

VAL CONTROLS

Intelligent Valve Control



Increased safety for ESD valves

IDC24

Intelligent Diagnostic Controller

Val Controls A/S

Intelligent valve control based on the latest know-how concerning digital technology for advanced valve control, monitoring and testing suited for pneumatic and hydraulic actuators. Our key task is to assist valve and actuator manufactures in finding the optimal solution for control, monitoring or testing of their products. We discover the best solutions for hazardous areas and harsh environments combined with cost reduction potentials.

Index

Presentation	3
Standard ESD vs IDC24.....	4
IDC24-F.....	5
IDC24-AF - standard	6
IDC24-AF - custom.....	7
IDC24-A	7
Diagnostic	8
Partial stroke signature.....	9
Full stroke and ESD signature	10
Solenoid Valve Test.....	10
Val Controls Diagnostic Centre.....	11
Safety Integrity Level.....	13
Advanced diagnostic	14
Stand alone	14
HIPPS integration.....	15
User interface	16
MTCControl	16
Control stations	17
Specifications	18
Model selector – IDC24-F.....	20
Model selector – IDC24-AF	21
Model selector – IDC24-A.....	22

Presentation

The IDC24 from Val Controls is an Intelligent Diagnostic Controller. To be used for valve testing and operation. It has an integrated microprocessor with very flexible software, so the controller fits almost any hydraulic and pneumatic, rotary and linear, double acting and spring return actuator on the market.

Based on many years of experience with valve testing, we have built this function in the product as standard. Now you have the opportunity to have a diagnostic of the valve, while it is in use. By performing a PST on a valve in operation and compare the performance data with the data from the reference stroke the current state of the valve system can be determined and the maintenance can be adjusted.

- **Partial Stroke Testing, PST**
- **Full Stroke Testing, FST**
- **Solenoid Operated valve Testing, SOT**
- **Optional automatic full stroke test during ESD, EST**
- **All tests with valve signature of position, pressure can be added as option**

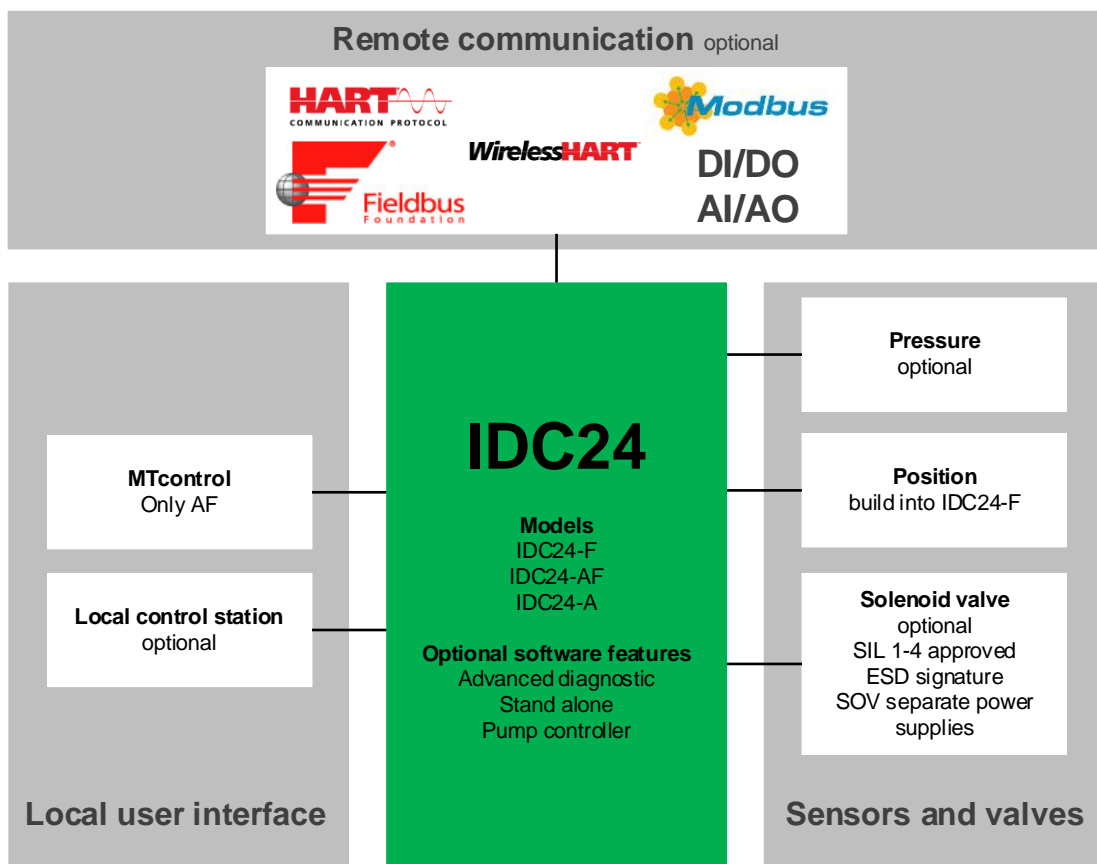

Standard ESD vs IDC24

A standard ESD system is usually only tested during shutdown or when an emergency occurs. The problem is that the system cannot be tested when the factory is running, since it can disturb the process and can give problems reaching the maximum production capacity.

A standard ESD system can be designed as shown in the picture below. The ESD system will de-energize the solenoid valve and the valve will close.

Standard ESD system



The IDC24 from Val Controls can be used on already installed systems with few modifications. It is easy to add the ability for extra testing, security and diagnostic. The picture below shows how the IDC24 can be added to an existing system or used in a new installation.

Standard ESD system with IDC24

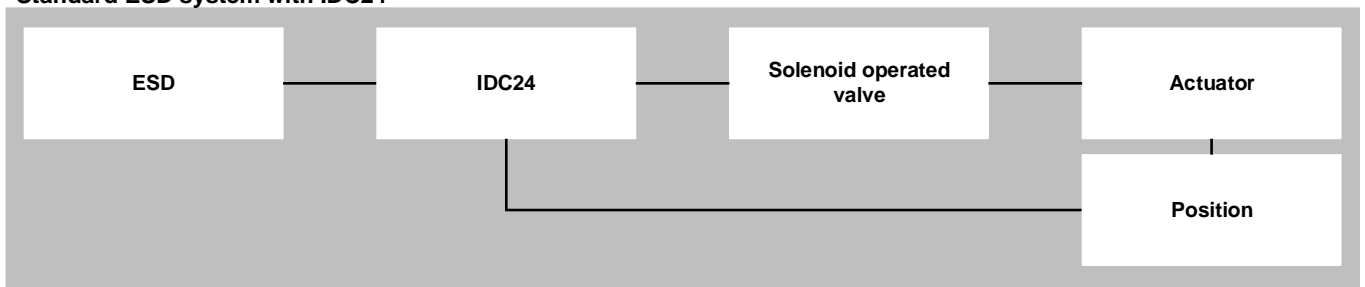

IDC24 Intelligent Diagnostic Controller

IDC24-F

This Flameproof is an IDC24 with a build in non-contact position transmitter. It is used for controlling and diagnostic on on/off valve systems.

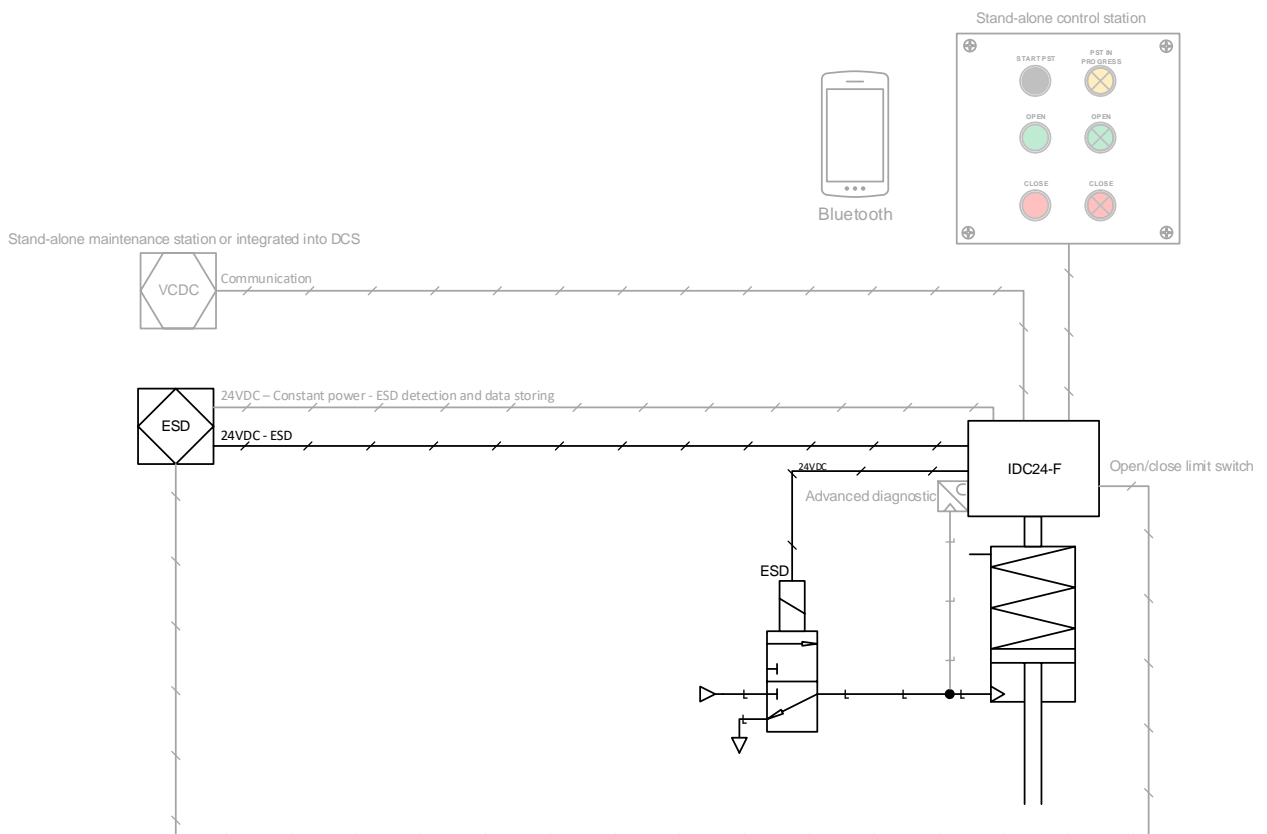
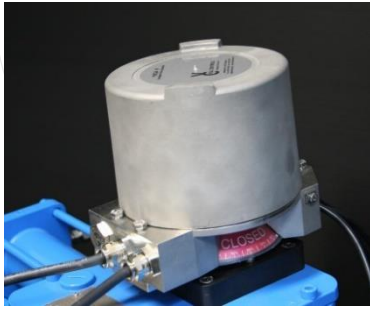

Greyed areas are options

IDC24-AF - standard

The Advanced Flameproof model is designed around a SS316L flameproof enclosure

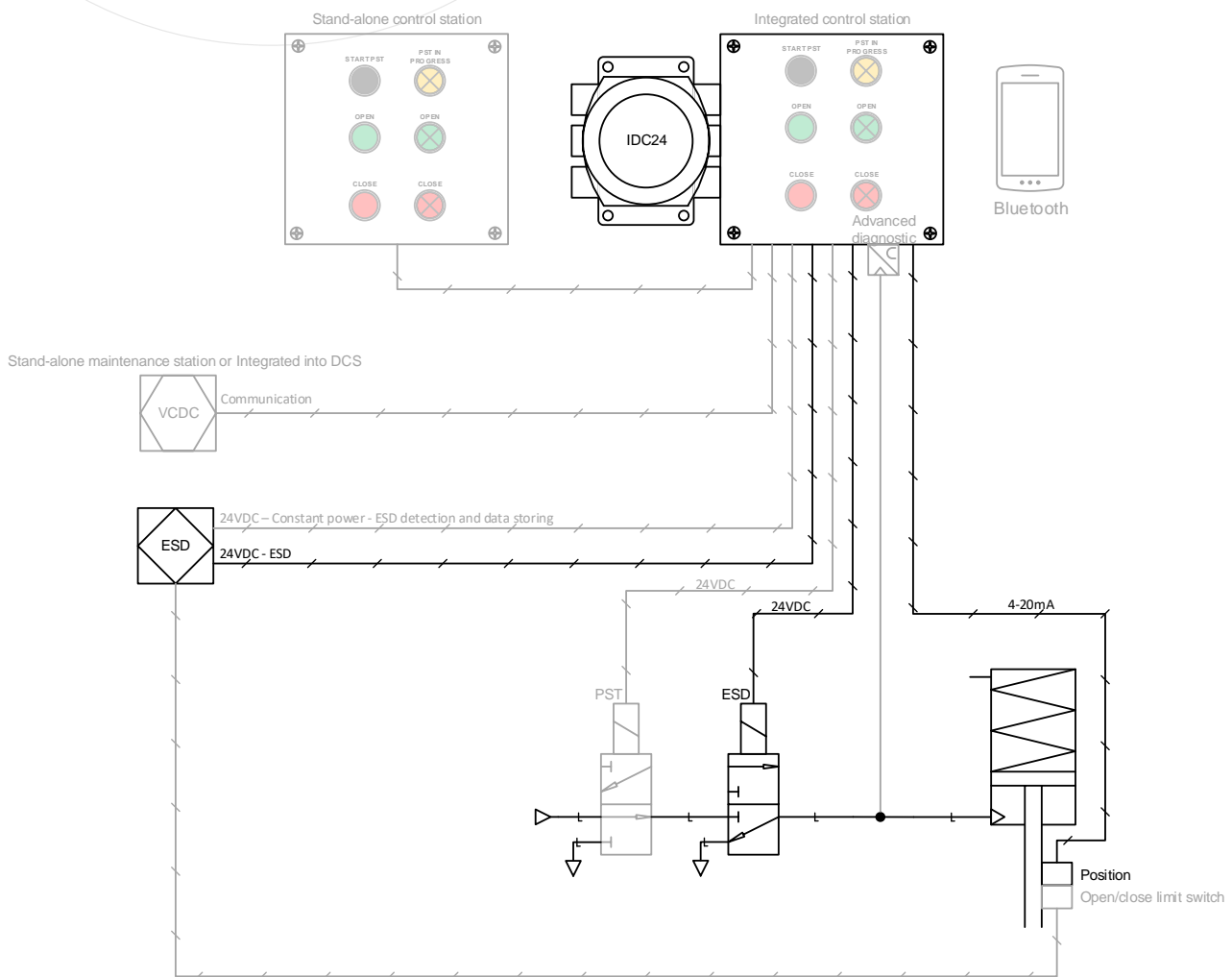

Greyed areas are options

IDC24-AF - custom

This model is for customers with very high demands for performance and connection possibilities. This unit is very flexible and can be configured to almost any customers needs and can be easily expanded, e.g. with a backup battery or other advanced features.



IDC24-A

This model is for customers with very high demands for performance and connection possibilities. This unit is very flexible and can be configured to almost any customers needs and can be easily expanded, e.g. with a backup battery or other advanced features. The IDC24-A is intended for already installed systems or customers who have their own housing and installation.



Diagnostic

Basic diagnostic can be performed directly on the IDC24 display and keyboard. For more detailed diagnostic, the test data must be transferred to Val Controls Diagnostic Centre.

The IDC24 can perform the following test:

- **Partial stroke test – PST**
- **Full stroke test – FST**
- **Solenoid valve test – SOT**
- **Emergency shutdown test - EST**

The IDC24 makes a valve signature during the following tests:

- **Partial stroke signature**
- **Full stroke signature**
- **Emergency stroke signature**

All graphs can show valve position and actuator pressure. This makes the IDC24 able to find parameters that can show the condition of the valve. Some of the parameters, which can be used to detect possible problems, are:

- **Breakaway time**
- **Travel time**
- **Breakaway pressure**

Some of the problems that the IDC24 can be used to identify includes:

- **Slow reacting or stuck solenoid valves**
- **Slow moving or stuck valve**
- **Increased stem friction**
- **Broken spring in actuator**
- **Long reaction time**

Partial stroke signature

A partial stroke test will de-energize the solenoid valve until the valve position is at a specified point. Then the solenoid is energized to return the valve to the normal operation.

An example of a partial stroke signature for a pneumatic system is shown below.

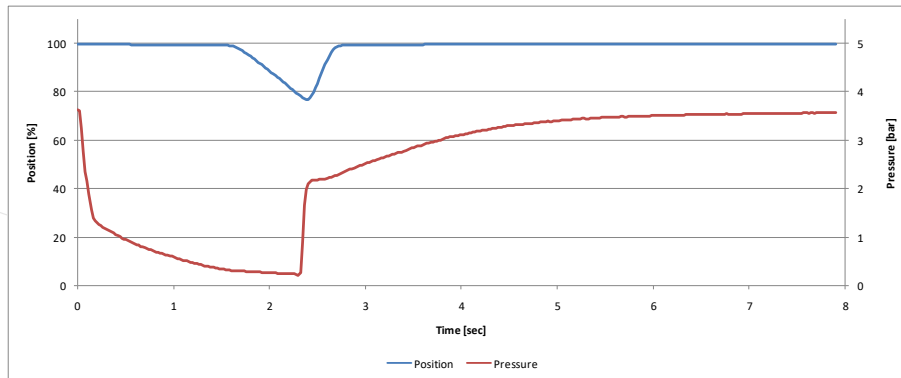

This signature contains both position and pressure.

The breakaway occurs after 1.6 seconds when the position goes below 99%.

Travel time for the partial stroke is 0.6 seconds, which is the time it takes the valve to move from 99% to 80%.

Changes in these measured times indicates that there might be a problem with the valve or actuator.

The pressure graph is another aid to diagnostic the system. Breakaway pressure shows if extra force is necessary to move the valve.

Full stroke and ESD signature

A full stroke test closes the valve completely and records the signature.

A full stroke signature of the same system as above is shown here.

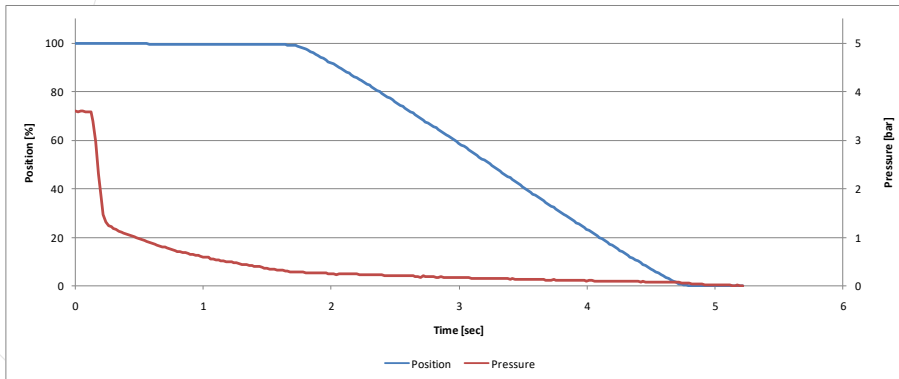

The breakaway is again measured to 1.6 seconds and the signatures are similar until the position reaches 80%.

Travel time for the full stroke takes 3.0 seconds.

Solenoid Valve Test

The IDC24 includes a solenoid valve test function to diagnose the solenoid valve. This test de-energizes the solenoid valve for a short period while measuring the pressure drop in the hydraulic or pneumatic system.

The test can be performed without moving the valve.

Val Controls Diagnostic Centre VCDC

Val Controls Diagnostic Centre for evaluating partial stroke, full stroke and solenoid test.

By using Val Controls Diagnostic Centre it is possible to:

- See test results and valve signatures
- Compare valve signatures
- Live control and monitoring of the valve system
- Generate test reports

Each recorded signature can be examined graphically by the operator. The recorded signatures can be selected from a list based on the date and time it was recorded.

Up to six signatures can be visually compared by selecting them from the lists. This enables the operator to see how the system has performed compared to earlier tests. If the graphs evolve in one direction over time, the report indicates wear in the system.

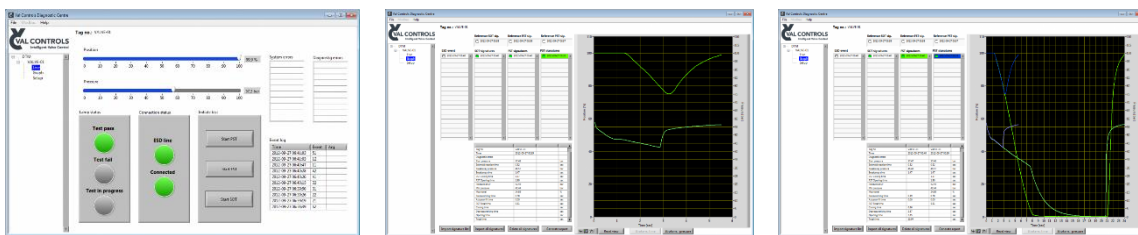

The IDC24 records several performance information during the tests. Together with the valve signatures these can be compiled to test reports. The reports are easy to customise with the needed data as well as logo and customised header and footer.

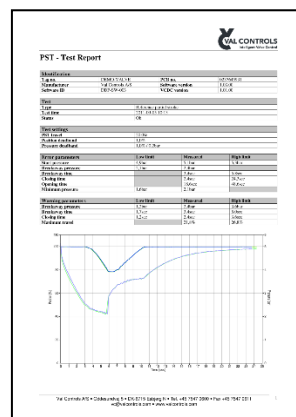

IDC24 Intelligent Diagnostic Controller

VCDC can be used with the following communication types:

- **HART and WirelessHART, delivered with certified DTM and DD**
- **Modbus**
- **USB**
- **Offline**
- **Memorycard**



Safety Integrity Level

The IDC24 is designed to be used in safety instrument systems for partial stroke testing of emergency shutdown valves with no negative impact on the safety function. The IDC24 does not adversely affect the execution of the safety function.



IDC24-F

The IDC24-F can control one solenoid valve from either one power supply or two power supplies, one for the solenoid valve and one for the unit.

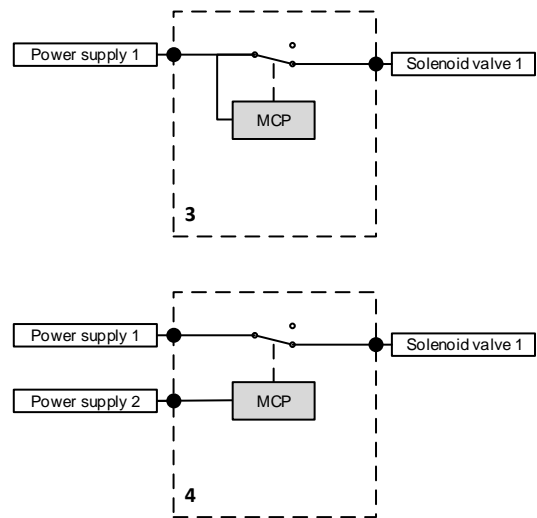

IDC24-AF standard

IDC24-AF standard can control up to two solenoid valves either from one power supply or by two separate power supplies.

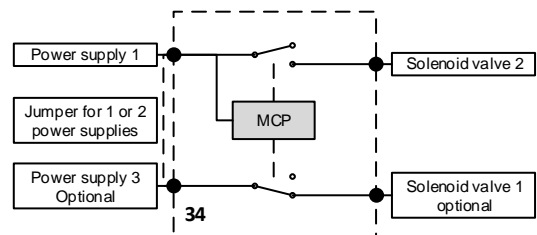

IDC24-AF custom and IDC24-A

The IDC24-AF custom has the option to control up to two solenoid valves. It can have up to three power supplies, one for each solenoid valve and a separate for powering the unit. Both relays controlling the solenoids valve can be configured to be either NO or NC.

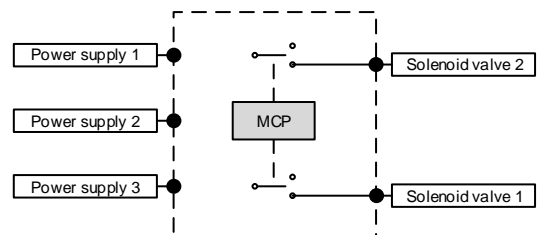

Timestamp

The timestamp feature adds a watch with battery backup.

Advanced diagnostic

Advanced diagnostic adds the possibility to add a pressure transmitter measuring the pressure in the actuator.

This gives more diagnostic possibilities like actuator force.

Stand alone

The stand alone feature adds the following features:

- **Internal memory up to +50.000 logs and signatures**
- **Watch with battery backup**
- **Scheduler**

This gives the possibilities for the IDC24 as a total stand alone unit capable to log all events and record all valve signatures.

User interface

Model AF and A has the following features in the user interface:

- **USB connection**
- **Graphical display**
- **4 button keyboard**
- **Status indicators:**
 - **Open/closed**
 - **ESD**
 - **Local**
 - **Pump**
 - **MT locked (only AF)**
 - **Test pass**
 - **Test fail**
 - **Test in progress**



MTControl

When IDC24-AF is installed in hazardous area, opening of the enclosure is not allowed, so it is not possible to operate the unit using the keyboard. By adding MTControl to the unit, it is now possible to operate the keyboard through the glass window of the enclosure using a magnetic pen. MTControl locks automatically after use, to provided unattended use.



Control stations

Integrated or stand-alone

All control stations is installed directly on the terminal box or as stand-alone.

Standard control station

Control station for advanced control of ESD system with PST.

Button 1: Start PST	Lamp 1: PST in progress
Button 2: Open	Lamp 2: Open
Button 3: Close	Lamp 3: Close

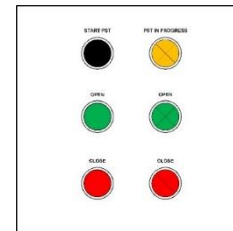

Compact control station

Simple control station for PST systems.

Button 1: Start PST	Lamp 1: PST in progress
---------------------	-------------------------

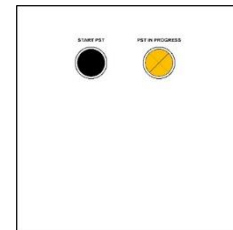

PST and reset control station

Control station for advanced control of ESD system with PST and with reset.

Button 1: Valve open	Lamp 1: Open
Button 2: Valve close	Lamp 2: Close
Button 3: Valve test	Lamp 3: Ready to reset

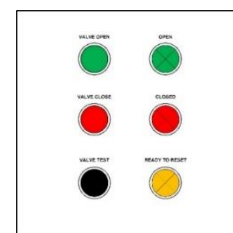

Customized control station

Control station can be fully customized to customer specifications.

All control stations is available with unlimited number of buttons and lamps.

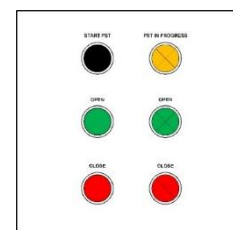

Specifications

IDC24-F

Dimensions lwxh: 177x150x150mm

Weight: 6kg

Ex approval: ATEX/IECEX - II 2 GD Exd [ib] IIC T4-T6

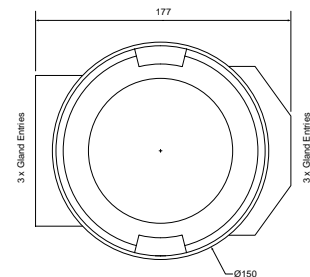

IDC24-AF standard

Dimensions lwxh: 337x200x160mm

Weight: 7kg

Ex approval: ATEX/IECEX - II 2 GD Exd IIC T4-T6

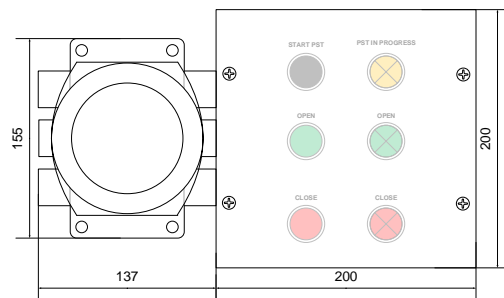

IDC24-AF custom

Dimensions lwxh: custom

Weight: custom

Ex approval: custom

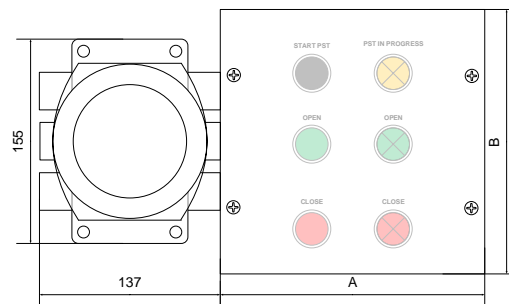

IDC24-A

Dimensions lwxh: 157x116x58mm

Weight: 0,5kg

Ex approval: None

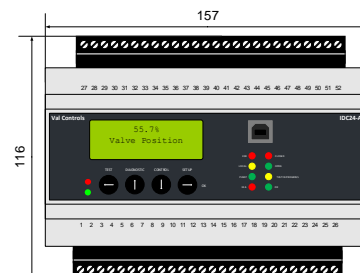

IDC24 Intelligent Diagnostic Controller

Model	F	AF Standard	AF Custom	A
Valve control				
Hydraulic or pneumatic - Spring Return or Double Acting actuator	•	•	•	•
Automatic intelligent or manual calibration	•	•	•	•
Error and event log	•	•	•	•
Standard diagnostic				
PST, FST and EST test with signature	•	•	•	•
Solenoid valve test	•	•	•	•
PST overshoot protection and random test set point	•	•	•	•
Configurable alarms and errors	•	•	•	•
Interval scheduler	•	•	•	•
Advanced functions				
Timestamp	○	○	○	○
Advanced diagnostic with pressure sensor	○	○	○	○
HIPPS integration test and verification functions	○	○	○	○
Pump unit controller	○	○	○	○
Stand alone				
Integrated scheduler	○	○	○	○
Timestamp - internal watch with battery backup	○	○	○	○
Local storage of all signatures – microSD card	○	○	○	○
Diagnostic software				
Val Controls Diagnostic Centre - HART/Modbus/USB/offline/memory card	○	○	○	○
VCDC scheduler	○	○	○	○
Certified DTM and DD	○	○	○	○
SIL				
SIL 4	•	•	•	•
ESD detection and data storing – 2x24VDC power supply	○	○	○	○
Separated power supply for solenoids - 3x24VDC power supply	○	○	○	○
Local user interface				
Display with menu	•	•	•	•
Indication LEDs	•	•	•	•
USB connection	•	•	•	•
MTControl	•	•	•	•
Communication				
AO: 4-20mA transmitter loop (position or pressure)	○	○	○	○
AO: 4-20mA transmitter loop (position or pressure) with HART v.7	○	○	○	○
Modbus RTU – RS-485	○	○	○	○
Foundation Fieldbus H1	○	○	○	○
Wireless HART	○	○	○	○
Other communication protocols on request	○	○	○	○
Local control panel functions				
Remote/local-open/close operation	○	○	○	○
Local position indicator: Open/close	○	○	○	○
Local reset: Ready to reset and reset	○	○	○	○
Local PST, FST, SOT: Start, Abort, In progress, Pass and Error	○	○	○	○
In and outputs				
AI: 4-20mA position transmitter	Build-in	1	1	1
AI: 4-20mA pressure transmitter	1	1	1	1
Power supply – unit power consumption <2W	1-2	1-2	1-3	1-3
Solenoid drivers	1	2	2	2
DO: Digital output	3	3	6	6
DI: Digital input	3	3	4(17)	4(17)
AI: 4-20mA control loop	1	1	1	1
AO: 4-20mA output			(2)	(2)
AI: 4-20mA sensors			3	3
3-wire potentiometer			1	1
Design				
Temperature range	-40°+85°	-30°+60°	-50°+80°	-40°+85°
Ingress protection	IP66/67	IP66	IP65-68	IP20
Flameproof – ATEX and IECEx	•	•	•	•
Enclosure material	SS316	SS316L	-	Plastic
Configuration software				
Configurable by ValConnect software using USB	•	•	•	•

Standard = •
optional = ○

Model selector – IDC24-F

Product name	Type	Communication 1	Communication 2	Power supply	Limit switch	Enclosure	Conduit entries	Indicator	Ex certification	Software features
IDC24	F	A1	A2	B	C	D	E	F	G	H

A1	Communication 1
0	None
1	HART – Control loop
2	HART – Transmitter loop
3	Modbus RTU
4	Foundation Fieldbus H1
5	Wireless HART
A2	Communication 2
0	None
B	Power supply
0	None
3	SIL 4 approved
4	SIL 4 approved + ESD signature
C	Limit switch, see table below
0	None
1	2 x SPDT V3 Mechanical
2	2 x SPDT Reed Type Proximity – Rhodium
3	2 x V3 Namur Type Inductive Proximity – P&F NJ2-V3-N
D	Enclosure
S	SS316
L	SS316L
E	Conduit entries
1	6 x M20x1,5
2	5 x M20x1,5 – 1 x M25x1,5
5	6 x ½"NPT
F	Indicator
0	None
1	90° red closed/green open
G	Ex certification
I	Ex d ib – Non I.S. components
A	Ex d ib – ATEX only
B	Ex d ib – ATEX and IECEx
H	Software features
-	None
A	Timestamp
C	Advanced diagnostic using pressure sensor
D	Stand alone
OA	2 x Maxx Guard Reed Type Proximity, is chosen together with 2 in Limit switch
OB	3 x SPDT Reed Type Proximity – Rhodium, is chosen together with 2 in Limit switch
I	Custom identification
XX	To identify custom made units

Model example: IDC24-F-1033S11B

Limit switch	V3 Mechanical Switches	Mag Prox Reed Switch	P&F - NJ2-V3-N	Maxx Guard switch
Configuration	SPDT	SPDT	Namur inductive	SPDT
Contact material	Silver Plated Steel	Solid Rhodium		Rhodium
Current ratings	16 Amp @ 125 or 250 VAC 0.6 Amp @ 125 VDC 0.3 Amp @ 250 VDC	1 Amp max.	Target On - <1 mA Target Off - >3 mA	Steady State 0-0.30 A Switched max. 0.30 A Inrush max. 1A Leakage 0A
Power Rating	-	10W/VA	-	
Voltage	-	Max. 120V AC/DC	5 VDC (5-25VDC)	Max. 48 VDC / 125 VAC
Voltage Drop max.				0.1V @ 10 mA 0.5 V @ 100 mA
Temperature range	-40°C to +80°C	-40°C to +80°C	-25°C to +100°C	-40° C to + 85° C

Model selector – IDC24-AF

Product name		Type	Terminal box	Control station		Communication 1	Communication 2	Expansion card		Software features
IDC24	-	AF	A1	A2	-	B1	B2	C1	-	D

AF - standard	
A1	Terminal box
-	Standard terminal box
A2	Control station
-	None
S	Standard control station
C	Compact control station
R	PST and reset control station
B1	Communication 1
00	None
11	HART – Transmitter loop
21	Modbus RTU
B2	Communication 2
00	None
C1	SIL expansion card
34	SIL 4 approved + SOV separate power supplies – NO/NC
D	Software features
-	None
A	Timestamp
C	Advanced diagnostic using pressure sensor
D	Stand alone

Model example: IDC24-AF-110034-C

Model example: IDC24-AFL-110034-C-JA

Model selector – IDC24-A

Product name		Type		Communication 1	Communication 2	Expansion card 1		Software features
IDC24	-	A	-	B1	B2	C1	-	D

B1	Communication 1
00	None
10	HART – Control loop
11	HART – Transmitter loop
12	Wireless HART
21	Modbus RTU
30	Foundation Fieldbus H1
B2	Communication 2
00	None
C1	Expansion card
00	None
01	2 x AO (4-20mA - active) and 2 x DI
02	4 x DI
03	2 x AO (4-20mA - passive) and 2 x DI
1X*	SIL 4 approved
2X*	SIL 4 approved + ESD signature
3X*	SIL 4 approved + SOV separate power supplies
4X*	SIL 4 approved + ESD signature + SOV separate power supplies
D	Software features
-	None
A	Timestamp
C	Advanced diagnostic using pressure sensor
D	Stand alone
E	Pump controller
H	HIPPS integration
E	Custom identification
XX	To identify custom made units

Model example: IDC24-A-110034-C